

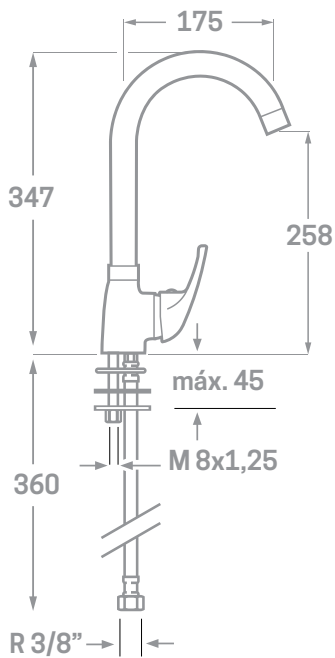

SERIE ENKEL / CARTUCHO CERÁMICO 40MM.

MONOMANDO FREGADERO CAÑO CISNE TIERRA FRANCIA



Ref. 23603TF

EAN 8435136001324



12 uds.



INFORMACIÓN TÉCNICA

- Acabado Tierra Francia.
- Cartucho cerámico 40 mm.
- Conexiones Flexitub con certificado AENOR M10x1-H3/8" x 350 mm.
- Atomizador de latón M24/100.
- Tornillos de fijación de acero inoxidable.



COMERCIAL
IMPORTACIONES
SANITARIAS

Partida Lloma Llarga, Pol. Industrial Sector 17, Parcela 5, 46119 Náquera, España.
www.cisval.com

Tel: 96 383 45 32. Fax: 96 350 03 47.